

4

3

2

1

Item	Quantity	Part number	Description
1	1	LowerMtgPlate - Bottom	
2	1	LowerMtgPlate - Upper	
3	1	BottomMold	
4	6	TopStrap	
5	1	WaveFlag	
6	10		Countersunk Bolt #10-24 x 1 Steel Grade 2 Black Oxide
7	36		Type A flat washer 3/8 Steel Grade 2
8	12		Round head short square neck bolt 3/8-16 x 3 Steel Grade 2
9	1	TopMold - Left	
10	4	TopMold - Mid	
11	1	TopMold - Right	
12	24		Hex nut 3/8-16 Steel Grade 2 Zinc Plated

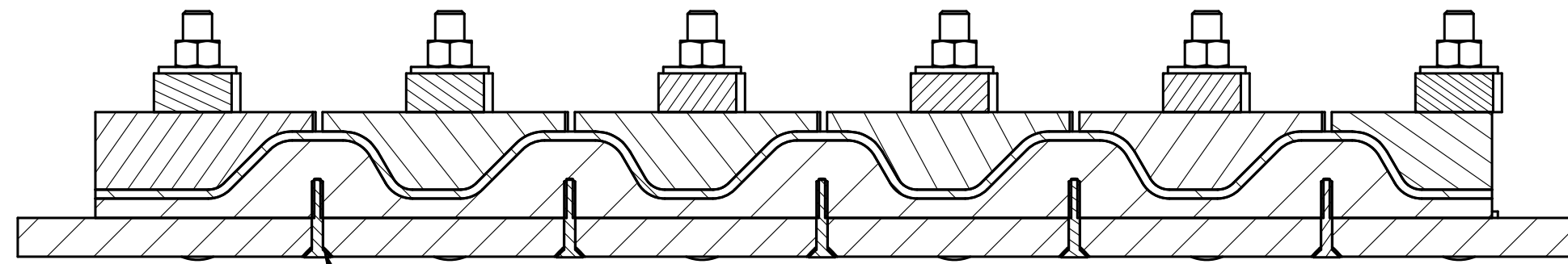

SECTION B - B

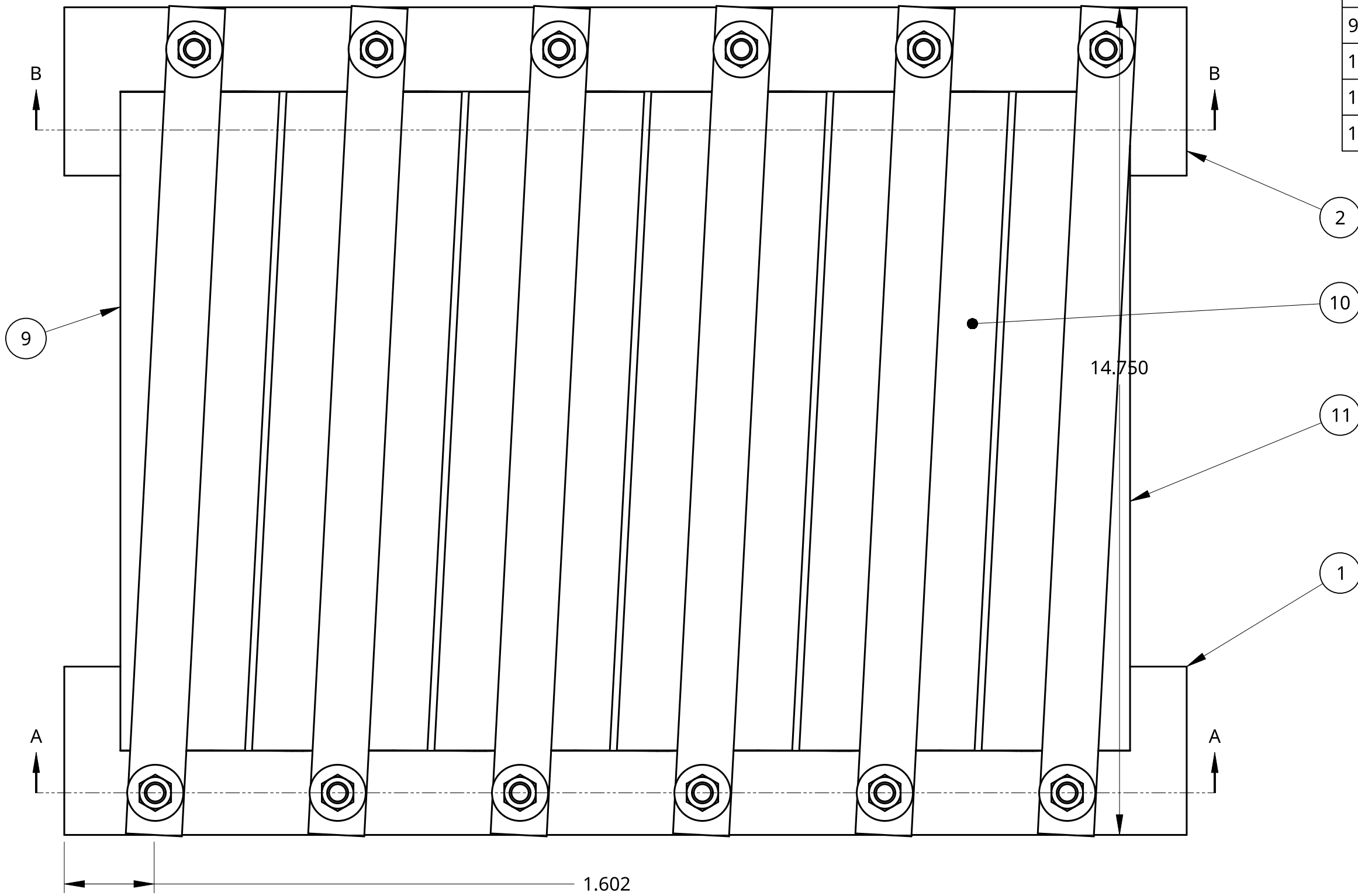

1.602

14.750

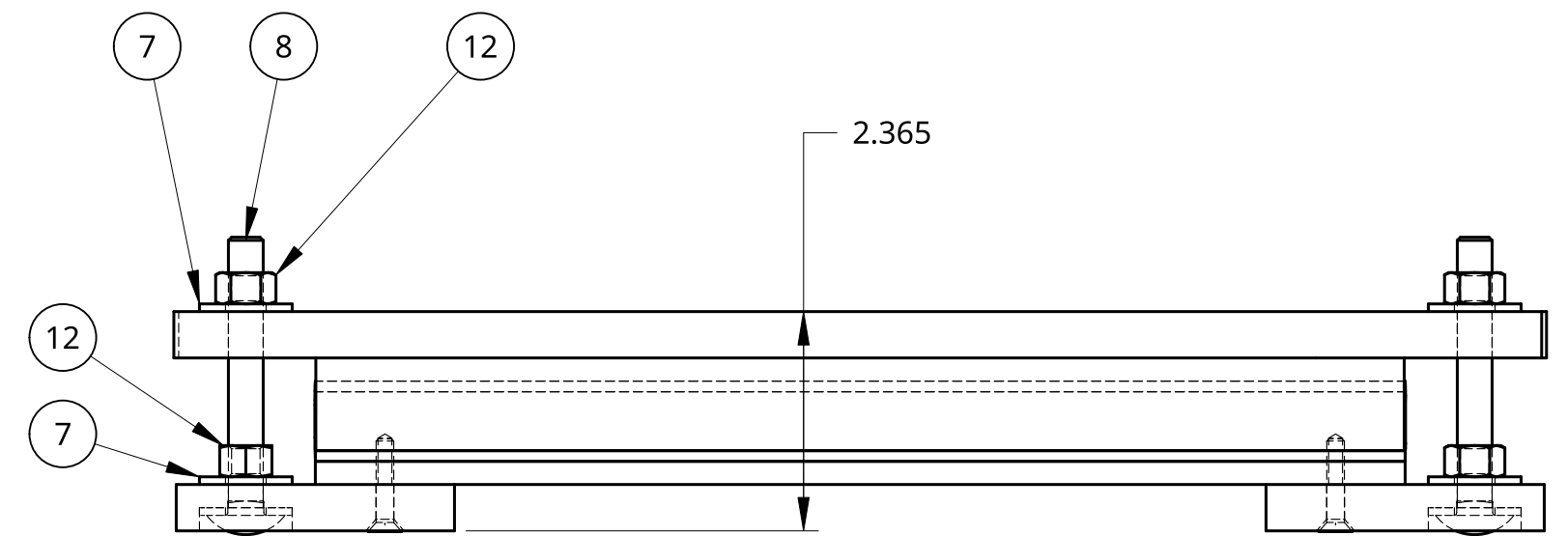
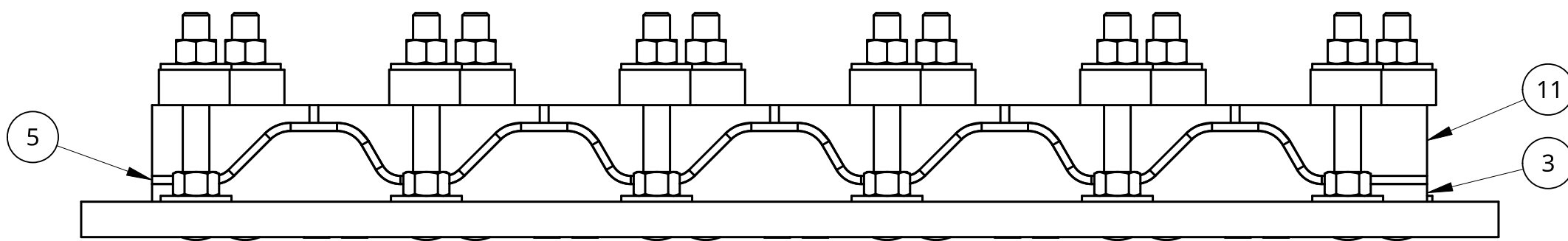

2.365

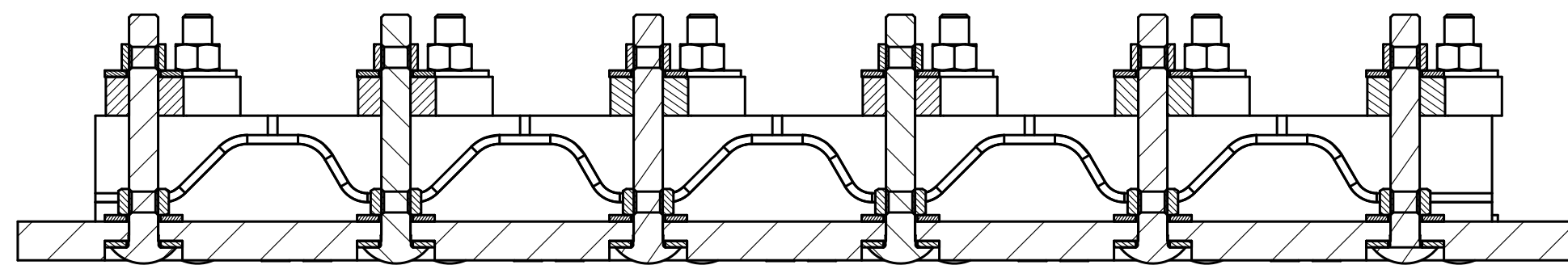

SECTION A - A

UNLESS OTHERWISE SPECIFIED, DIMENSIONS ARE IN INCHES		NAME	DATE	TITLE Flag Mold Assembly	
.XX = ±0-	ANGULAR = ±°	DRAWN	JAMES CLOSE		03/20/2024
.XXX = ±.00-	FRACTIONAL = ±	CHECKED			
.XXXX = ±.000-		APPROVED			
DO NOT SCALE DRAWING				C SCALE 1:2	
BREAK ALL SHARP EDGES AND REMOVE BURRS					DWG NO.
THIRD ANGLE PROJECTION		MATERIAL	FINISH	REV.	
				SHEET 1 of 2	

4

3

2

1

4

3

2

1

D

D

C

C

B

B

A

A

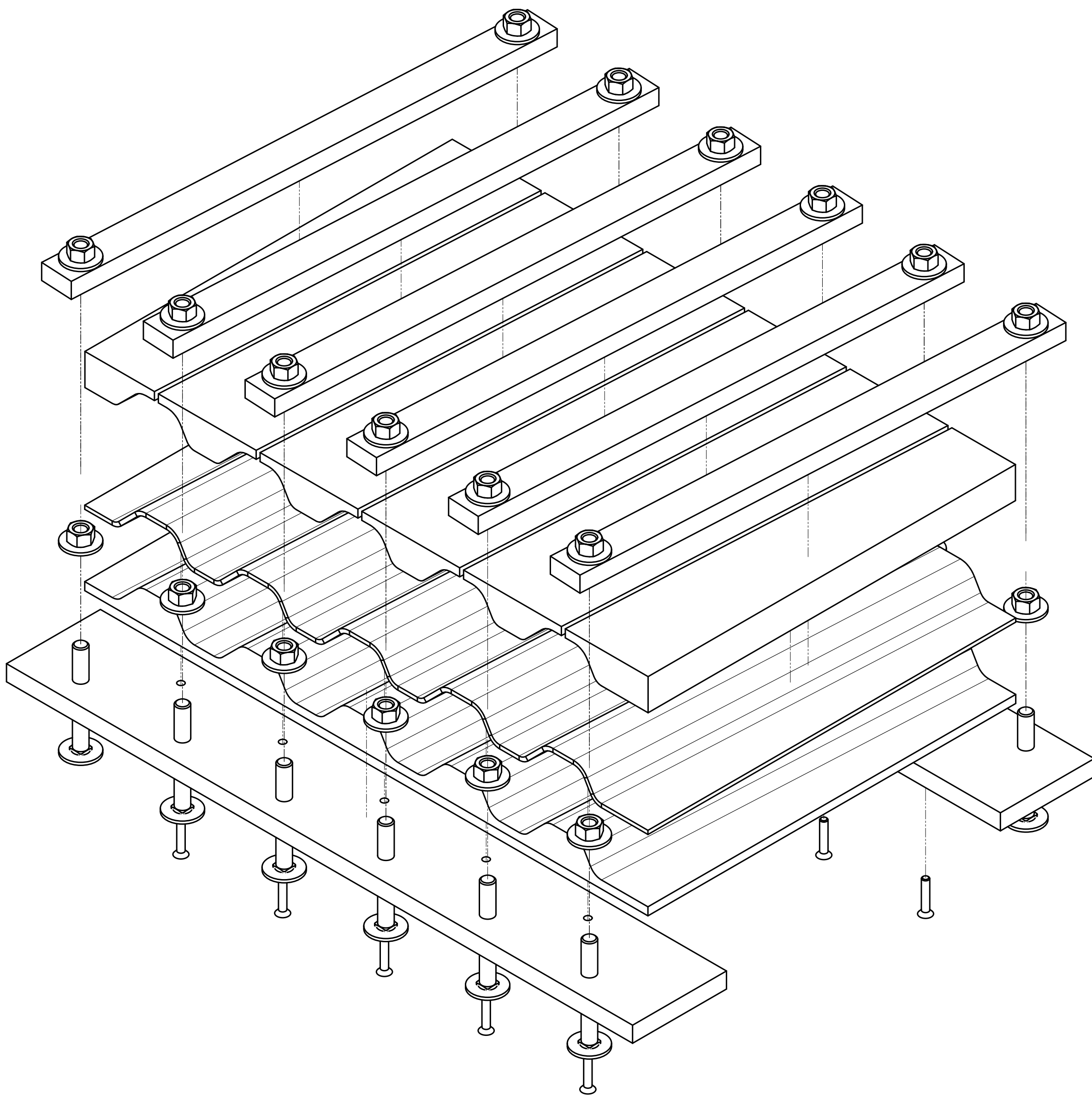

4

3

2

1