

Route **R** Plate™

User Manual

Model #03100/03101



JessEm

Tool Company

61 Forest Plain Road
Oro-Medonte, Ontario, Canada
L3V 0R4

Toll Free: 1-866-272-7492

Local: 705-726-6145

Fax: 705-327-0295

Email: jessem@jessem.com

Website: www.jessem.com

Thank you for choosing this product from JessEm Tool Company. We appreciate your support and hope that our product serves you well. This product is designed to provide many years of reliable service provided it is used as intended and taken care of.

This user manual will assist you in assembly and general operation of this product. It is not our intent to teach you about woodworking. It is assumed that you are an experienced woodworker with the basic skills and experience necessary to use this product safely. If after reading the following instructions, if you are unsure or uncomfortable about safely using this product we urge you to seek additional information through widely available woodworking books or classes.

IMPORTANT!

Read and understand the contents of this manual before assembly or operation of this product.

As part of our Continuous Product Improvement Policy, JessEm products are always advancing in design and function. Therefore there may be differences between what is shown in our catalogs, website or at retail display and what is sold at time of purchase. We reserve the right to make positive changes to our products at our discretion.

Suggested Router Bit Speeds

Bit Diameter	Max. Speed
1" (25mm)	24,000 RPM
1-1/4" - 2" (30-50mm)	18,000 RPM
2-1/4" - 2-1/2" (55-65mm)	16,000 RPM
3" - 3-1/2" (75-90mm)	12,000 RPM

IMPORTANT SAFETY PRECAUTIONS

- Before operating any router read and understand all safety instructions in the owner's manual that came with the router.
- If you do not have a manual, contact the manufacturer and obtain one before using any power tool.
- Always wear eye protection in compliance with ANSI safety standards when operating any power tool.
- Always use proper guards and safety devices when operating power tools and machinery.
- Carefully check router bits before each use. Do not use if damage or defect is suspected.
- Do not exceed the recommended RPM for any router bit.
- Do not wear loose clothing or jewelry that may catch on tools or equipment.
- Unplug the tool or machine when mounting or making any adjustments to mechanical performance.

ROUTER SAFETY PRECAUTIONS

- Never force the bit or overload the router beyond the expectations of the tool.
- Be sure that at least 3/4 of the shank length is inserted securely in the router collet.
- Never bottom out the bit in the collet. Allow 1/8" clearance between shank and bottom of collet.
- Always make sure the fence on your router table is locked into position before each use.
- Always rout in two or more passes when large amounts of stock must be removed.
- Use reduced RPM speeds for large diameter bits.

INSTALLING THE TAB-LOC INSERT RINGS

Your Rout-R-Plate comes with two phenolic insert rings, (1) with a 2" diameter bit hole and (1) with a 1-3/8" diameter bit hole which is also recessed to accept a standard template guide bushing. Additional ring sets are available with different diameter pre-drilled holes and/or no pre-drilled holes for creating your own custom centerhole diameters. See your JessEm distributor for these and other accessories.



FIG. 1

1. Place the insert ring into the centerhole of the Rout-R-Plate (Fig. 1).
2. With the insert wrench provided, insert the prongs of the wrench into the corresponding holes in the insert ring and turn the insert ring counter clockwise to tighten.
3. Turn the insert wrench clockwise to loosen and remove the ring. If the insert ring becomes too tight to loosen with hand pressure, a tap clockwise on the insert wrench with a block of wood will loosen it.

MOUNTING THE ROUTER

Included in these instructions are several diagrams showing the bolt patterns for various routers. Before referring to these diagrams check to see if your router has a removeable sub-base or base plate that can be removed and then used as a template for drilling the Rout-R-Plate.

If your router does not have a removeable sub-base that can be used as a drilling template refer to the diagrams included for laying out the hole pattern for your router.

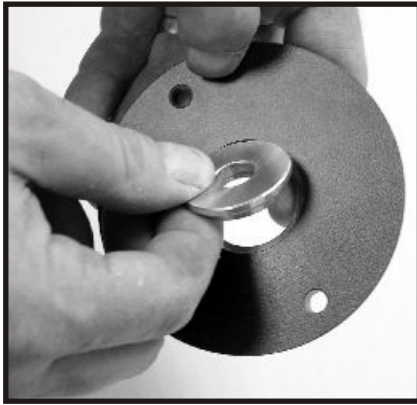

FIG. 2

USING THE ROUTER CENTERING BUSHING

1. Included with the Rout-R-Plate is an aluminum bushing that adapts to the 1-3/8" diameter insert ring. Install the bushing into the center of the 1-3/8" insert ring (Fig. 2).



FIG. 3

2. Install the 1-3/8" tab-loc phenolic insert with bushing into the Rout-R-Plate using the insert ring wrench provided (Fig. 3).



FIG. 4

3. Prop the Rout-R-Plate up on blocks of wood with the top side down to allow space under the plate for a router bit to pass through. Place a small piece of tape at the base of the router to use as a locator mark for the position of the router. Install a 1/2" diameter straight bit or spiral bit into your router's collet. Place the router on the plate with the 1/2" diameter bit projecting through the 1/2" hole in the bushing (Fig. 4). Rotate the router so that when the final installation is made, all router controls will be positioned for convenient access. Consider the final position of the power switch, height adjustment knobs, height lock lever, etc. The router handles should be oriented lengthwise or kitty corner to the plate or you may wish to remove the handles entirely for easy insertion and removal of the plate into the tabletop.



FIG. 5

4. With the router positioned to your satisfaction, use a pencil to trace an outline around the base of the router onto the Rout-R-Plate (Fig. 5). Also draw an intersecting mark on the tape and onto the plate to indicate the orientation of the sub-base for step 5.

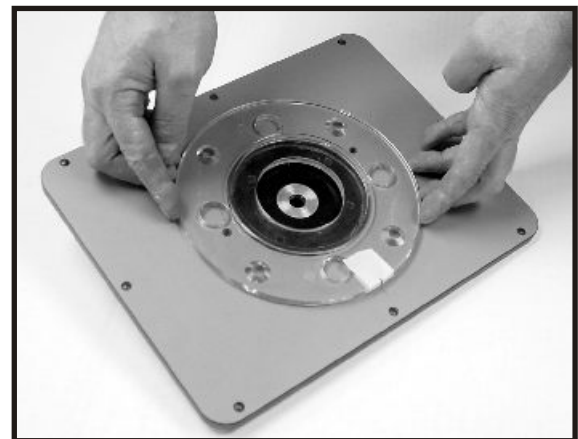

FIG. 6

5. Remove the router and then remove the sub-base from the bottom of the router. Then take the sub-base and center it within the circle you traced onto the Rout-R-Plate and also line up the intersecting lines on the tape and the plate to achieve the correct orientation of the router (Fig. 6).

6. Transfer the router mounting holes onto the Rout-R-Plate. Drill the holes and then counter sink holes on the top side of the plate so the bolt heads are below the surface of the top plate.

Note: You may need to use longer bolts to accommodate the thickness of the insert plate. Most of the bolt sizes are indicated in the diagrams on the following pages. Try a local hardware store or auto parts store for the hardware you need.

JESSEM TOOL LIMITED WARRANTY

All JessEm products are warranted to be free from defects in material and workmanship. JessEm will repair or replace any product which upon inspection proves to be defective for a period of (1) year from dated receipt and proof of purchase. All warranty claims should be made direct to JessEm Tool Company. Contact JessEm for a warranty claim return authorization and instructions to proceed. The consumer is responsible for shipping costs to return product to JessEm Tool Company. We will repair or replace the product at our discretion and JessEm Tool will return shipment to you at no charge.

WARRANTY LIMITATIONS

This warranty does not cover:

- Repairs or alterations made or attempted by anyone other than JessEm Tool Company or an authorized JessEm service professional.
- Normal wear and tear
- Abuse, misuse or neglect.
- Improper care or maintenance.
- Continued use after partial failure.
- Products that have been modified in any way.
- Products used with improper accessories.
- Premature thread wear due to adjusting height with electric or cordless drill.

FOLLOWING ARE DIAGRAMS SHOWING THE HOLE PATTERNS FOR SEVERAL POPULAR ROUTERS. YOU CAN USE THESE DIAGRAMS AS AN ALTERNATIVE IF THE PREVIOUS INSTRUCTIONS ARE NOT APPLICABLE TO YOUR ROUTER

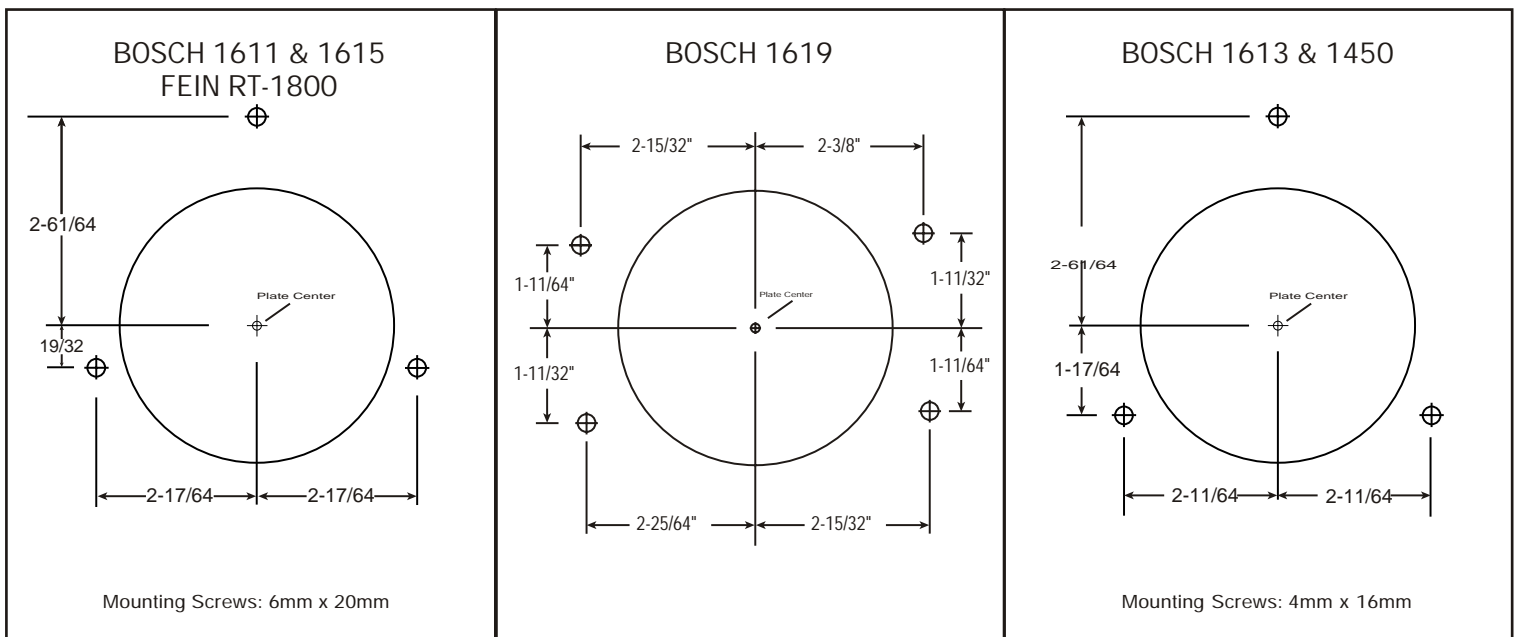

BOSCH 1604 & 1617EVS

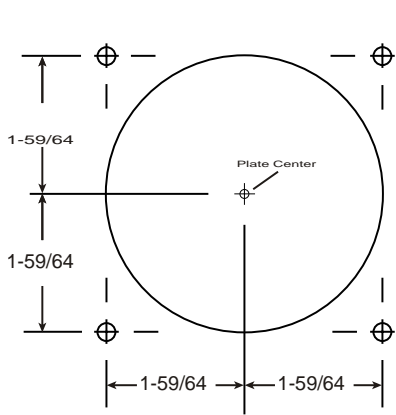

Mounting Screws: 4mm x 16mm

DEWALT 610 & ELU 2721

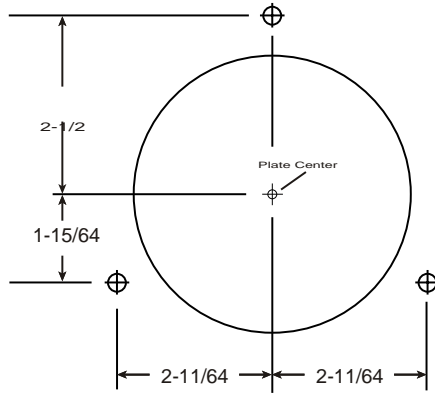

Mounting Screws: #8-32 x 3/4"

DEWALT 615

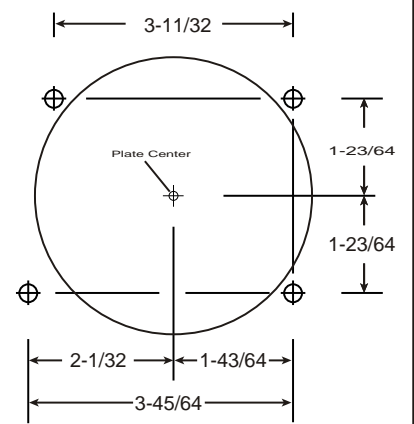

Mounting Screws: 4mm x 16mm

DEWALT 621

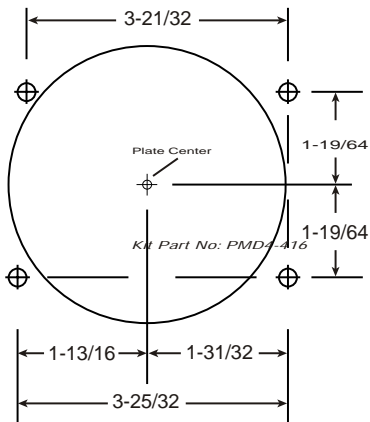

Mounting Screws: 4mm x 16mm

DEWALT 624, 625 & ELU 3337-9

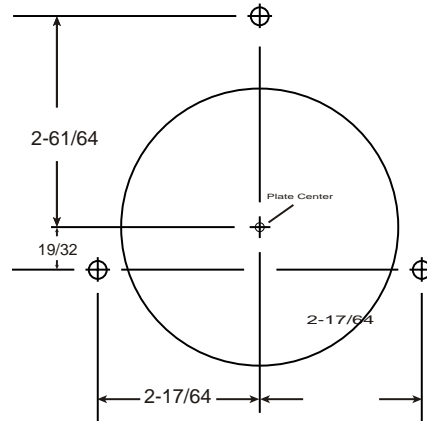

Mounting Screws: 6mm x 16mm

FREUD Ft2000

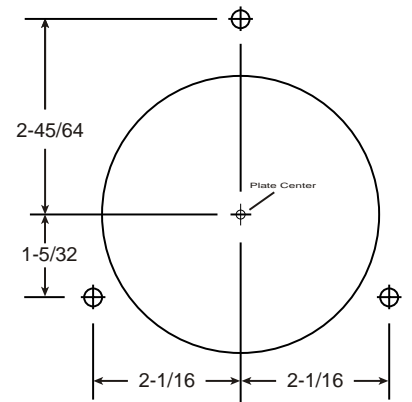

Mounting Screws: 6mm x 16mm

HITACHI M12V

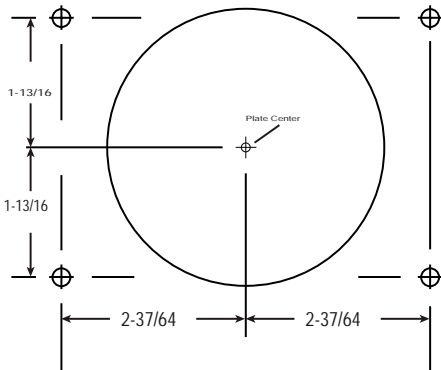

Mounting Screws: 5mm x 16mm

HITACHI TR12

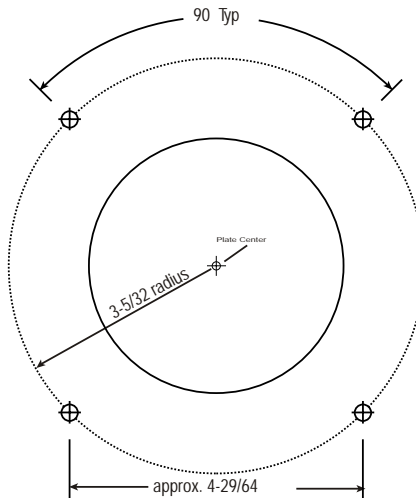

Mounting Screws: 5mm x 16mm

MAKITA 3612B, 3600

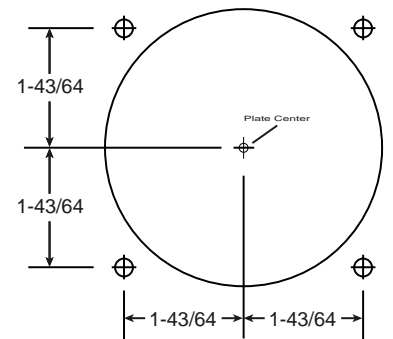

Mounting Screws: 4mm x 16mm

MAKITA 3621BR & C

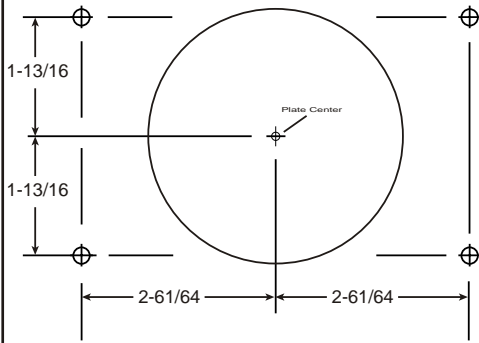

Mounting Screws: 4mm x 16mm

MILWAUKEE

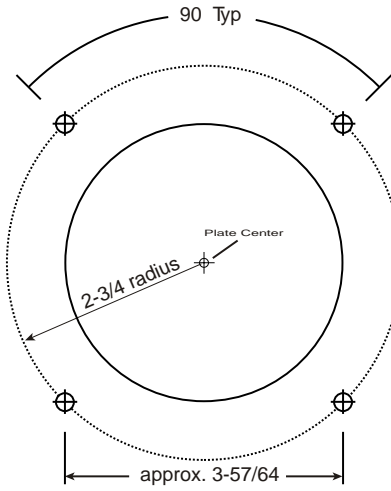

Mounting Screws: #8-32 x 3/4"

PORTER CABLE 100, 536, 690, 691, 692, 693

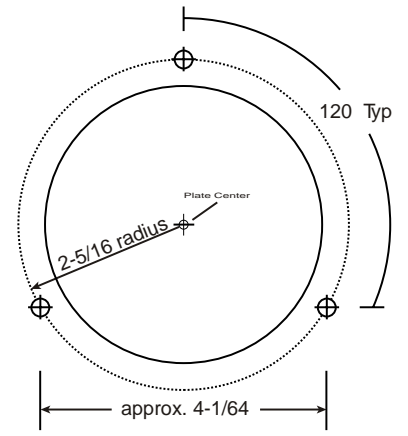

Mounting Screws: #10-24 x 3/4"

PORTER CABLE 518, 520, 7518, 7519, 7538, 7539

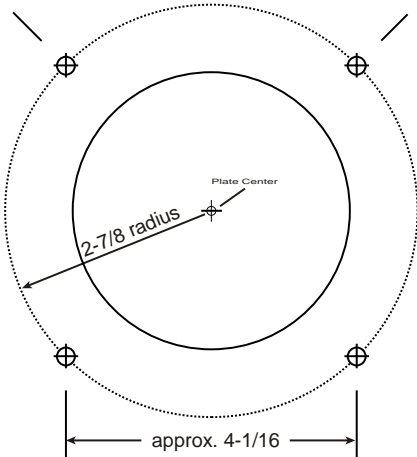

Mounting Screws: 5mm x 18mm

RYOBI 180

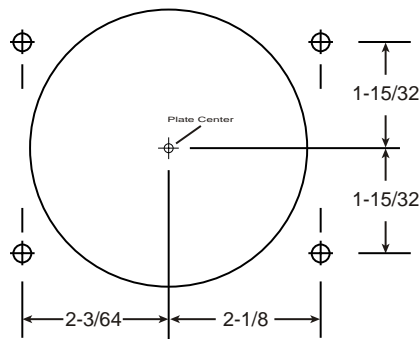

Mounting Screws: 5mm x 16mm

RYOBI RE-600 NEW

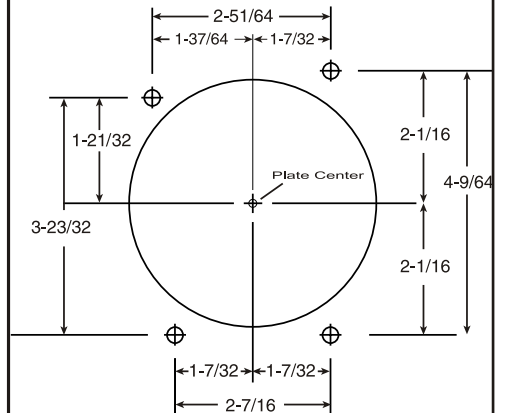

Mounting Screws: 8mm x 20mm

RYOBI RE-600 OLD, 500, 501

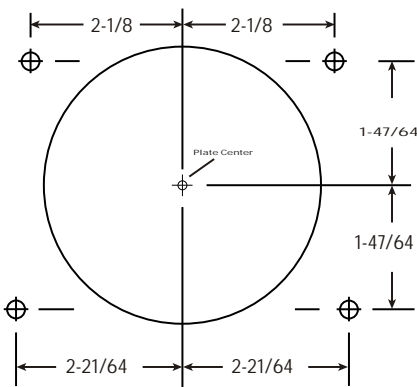

Mounting Screws: 4mm x 16mm

SEARS - 3 HOLE

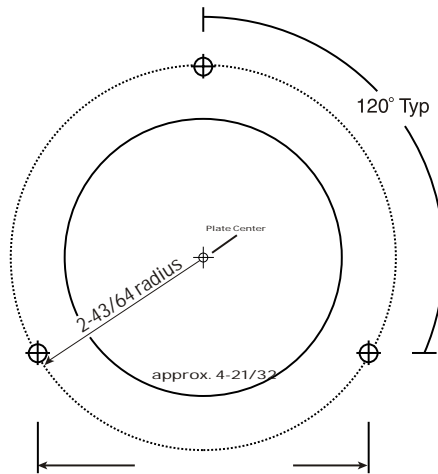

SEARS - 3 HOLE

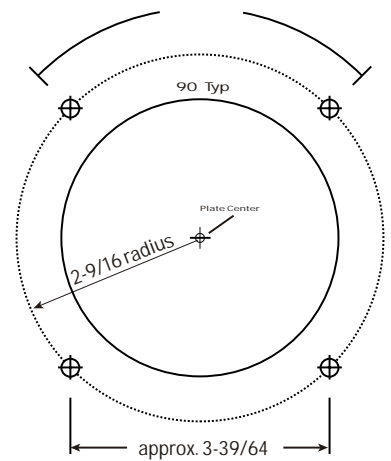

CUTTING A HOLE IN A CUSTOM TABLE

JessEm offers a solid phenolic table top pre-machined to accept the Rout-R-Plate, Mast-R-Plate, Rout-R-Lift FX and our Mast-R-Lift. However, if you are using a Rout-R-Plate in a custom table you need to machine the port in the table top to accept the Rout-R-Plate. Following are instructions to do so. Keep in mind that the Rout-R-Plate dimensions are the same as our Mast-R-Lift and Rout-R-LiftFX should you decide to upgrade to a precision height adjustment system in the future. We also offer a pre-machined template (item #03003) for routing the hole in your table top if you are not comfortable with the following instructions

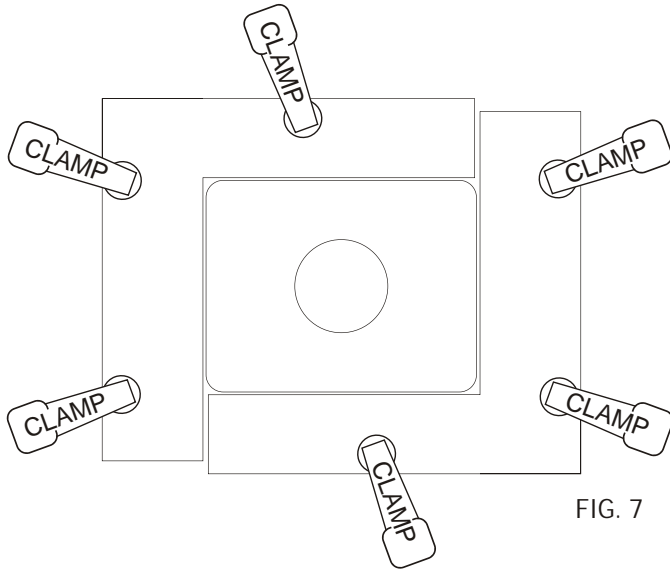

FIG. 7

1. Begin by positioning the Rout-R-Plate on the table top in the exact location you prefer it to be installed. Then position two "L" shaped templates you can fabricate from 3/4" MDF, plywood or particleboard so they surround the plate on all four sides (Fig. 7). Leave no more than 1/4" gap at the corners. Clamp the "L" shaped brackets securely to the table top or use double sided carpet tape. Be sure the placement of the clamps does not interfere with routing the inside hole in the table top.
2. Once your desired position of the Rout-R-Plate has been secured by the template jig you can remove the Rout-R-Plate from the table top.
3. You will need a 1-1/2" diameter pattern bit to achieve the 3/4" radius on the corners of the Rout-R-Plate. Several bit manufacturers offer this bit as a mortising/planer bit with top bearing and a 5/8" cutting length. You will be routing a groove approximately 13/32" deep (slightly deeper than the plate thickness of 3/8") to allow a slight excess of depth for plate leveling.

If you do not have the necessary bit or do not wish to purchase one, we do offer a pre-machined template for routing the hole with the use of 1/2" straight bit and a 3/4" template guide bushing. The Routing Template is item #03003 and can be purchased through any authorized JessEm distributor.

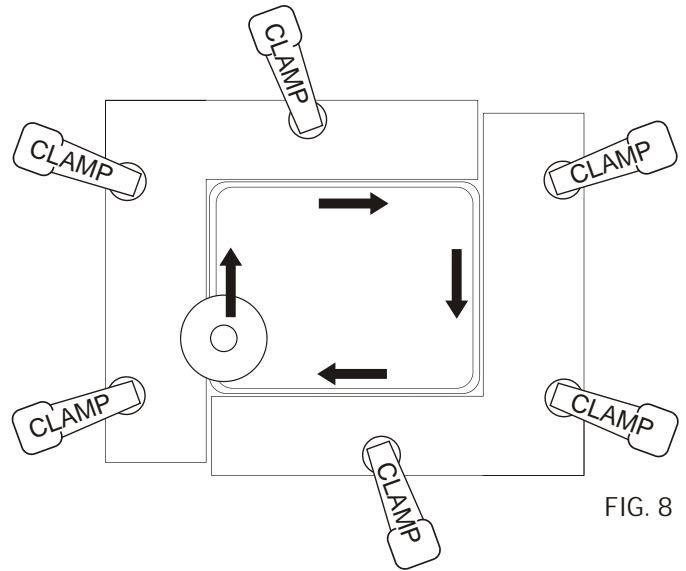

FIG. 8

4. You will need to remove the material in several passes for safety and a clean cut result. Begin by adjusting the cutting depth for making a 1/8" deep pass around the inside of the template. Then adjust the cutting depth another 1/8" deeper to take it down to 1/4" overall. Then adjust the cutting depth to slightly more than 3/8" for the final pass (Fig. 8).

5. Now remove the inner opening in the table top using a jigsaw. You want to leave a 1/2" ledge around the inside bottom edge of the hole for the Rout-R-Plate to sit on. Draw a cutting line 1/2 inch inside the outer edge of the groove you cut in step 4. Drill a starting hole anywhere within the waste area to start the jigsaw blade. Cut around the entire perimeter along your cut line to remove the center section and create the port for the router to go through. This completes the process of cutting the port for the Rout-R-Plate.

Before removing the routing template, check the fit of the Rout-R-Plate in the new opening. If it is too tight you can adjust one of the sections of the template and re-route where necessary or you can sand the edge of the Rout-R-Plate to achieve your desired fit. If too loose you can affix tabs/shims along the inside edge of the opening to achieve your desired fit.

Other Products From
JESSEM TOOL COMPANY

Mast **R** Lift Excel II™



Model # 02202

Mast **R** Lift™ II



Model #02120

Rout **R** Lift™ II

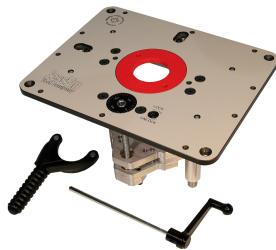

Model # 02310

Clear Cut Stock Guides

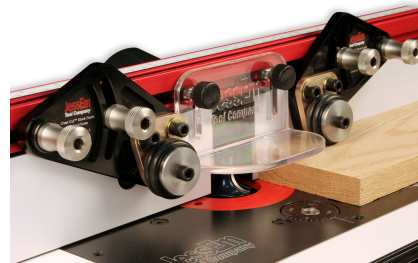

Model # 04215

JesseM
Tool Company

www.jessem.com

Tools That Make A Difference!